

### STYLE 16 TECHNICAL INFORMATION SHEET

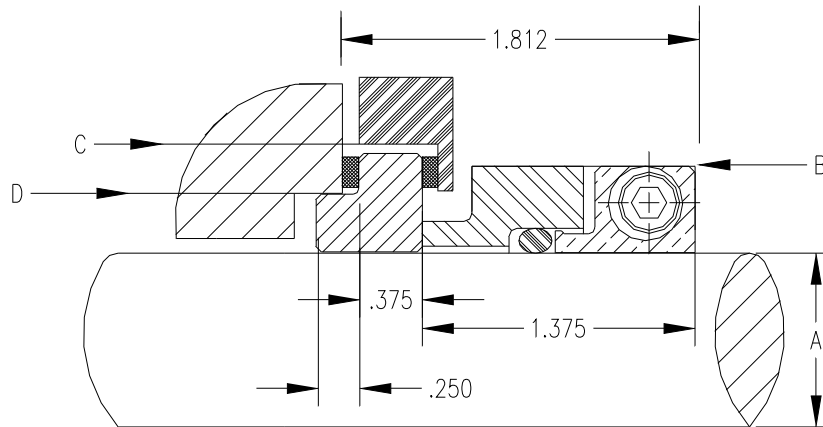

A	FLUIDOL SIZE CODE	B	C	D
SEAL SIZE		SEAL O.D.	GLAND COUNTER BORE	CLEARANCE MIN. OUTBOARD
.750	012	1.625	1.812	1.375
.875	014	1.750	1.937	1.500
1.000	016	1.875	2.125	1.625
1.125	018	2.000	2.250	1.750
1.250	020	2.125	2.375	1.875
1.375	022	2.250	2.437	2.000
1.500	024	2.375	2.750	2.250
1.625	026	2.500	2.875	2.375
1.750	028	2.625	3.125	2.500
1.875	030	2.750	3.250	2.625
2.000	032	2.875	3.500	2.750
2.125	034	3.000	3.750	2.875
2.250	036	3.125	3.875	3.000
2.375	038	3.250	3.937	3.125
2.500	040	3.375	4.125	3.250
2.625	042	3.500	4.250	3.375
2.750	044	3.625	4.375	3.500
2.875	046	3.750	4.562	3.625
3.000	048	3.875	4.625	3.750
3.125	050	4.000	4.750	3.875
3.250	052	4.125	4.937	4.000
3.375	054	4.250	5.062	4.125
3.500	056	4.375	5.187	4.250
3.625	058	4.500	5.312	4.375
3.750	060	4.625	5.437	4.500
3.875	062	4.750	5.562	4.625
4.000	064	4.875	5.687	4.750